

USERS MANUAL

CPT GEOTECH NOVA

(Electrical cone and piezocone penetration test)

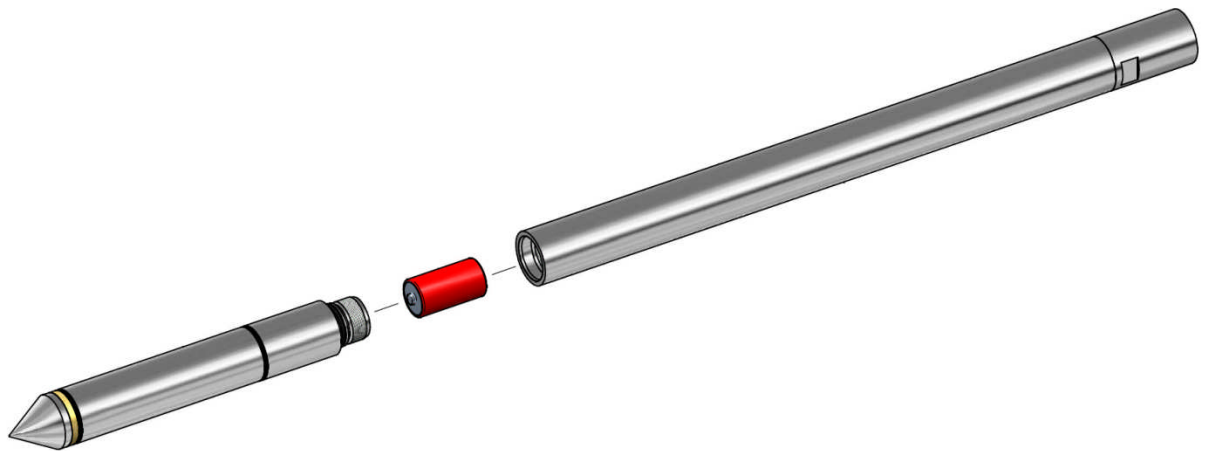

**Ingenjörfirman Geotech AB
Datavägen 53
SE-436 32 ASKIM (Gothenburg)
Sweden
Ph: +46 - 31 28 99 20
Fax: +46 - 31 68 16 39**

**E-mail: info@geotech.se
www.geotech.eu**

Published date: 2015-02-24

Table of Contents

1	General Information	1
1.1	Foreword	1
1.2	Safety	1
2	Product Information	2
2.1	General Description	2
2.2	Intended use	6
2.3	System components overview	7
2.4	CPTU probe	14
2.5	Transmitters and adapters	15
2.6	Surface equipment	15
2.7	SCPT equipment	19
2.8	Equipment for measuring electric conductivity	20
3	Preparations	20
3.1	Preparing the NOVA CPTU Probe	20
3.2	Preparation of wireless probe assembly	25
3.3	Preparation of cable probe assembly	26
4	Performing a test	27
4.1	Pre-drilling	27
4.2	Anchoring	27
4.3	Performing a CPTU test	27
4.4	Dissipation test	29
5	After test	29
5.1	Immediate actions	29
5.2	Uploading data from memory probe after test	34
6	Installation and system maintenance	35
6.1	Installation	35
6.2	Authorized Workshops	35
6.3	Trouble Shooting	36
	Notes	39

DOCUMENT HISTORY

Date	Comment	Sign
2009	Revised content.	
2013-10-22	Change of design and content, preliminary for proof reading	mcn
2013-11-05	New "beta" version published for a group of advanced users	mcn
2013-11-19	Beta version. Added actions to Trouble Shooting. Rod length corrected.	mcn
2014-04-14	Added actions to Trouble Shooting. Memory stick for software.	
	New jar for filter rings. Editorial corrections.	mcn
2015-02-24	Added information to 2.3. Revised 3.1. Editorial changes.	mcn

1 General Information

1.1 Foreword

This manual contains important information for the proper use and safe operation of the CPT GEOTECH NOVA equipment.

Read the manual carefully before you start operating the system. Also read the maintenance instructions before performing any maintenance work. The warranty from Ingenjörfirman Geotech AB (Geotech) is only valid if the instructions in this manual are followed.

Always keep the manual at the equipment and replace it immediately if it should become wholly or partially unusable. A new copy can always be ordered from Ingenjörfirman Geotech AB.

1.1.1 Content

The information in this publication is on the basis of information that was available at the time that the publication was written.

The information can change at any time. Ingenjörfirman Geotech AB reserves the right to change or update the content of the manual without prior notice.

1.2 Safety

The operator must be alert to potential hazards. The operator should also have the necessary training, skills and tools to perform these functions properly.

The important safety messages in this manual are presented as follows:

 **DANGER**

Indicates a hazardous situation which, if not avoided, will result in death or serious injury.

 **WARNING**

Indicates a hazardous situation which, if not avoided, could result in death or serious injury.

 **CAUTION**

Indicates a hazardous situation which, if not avoided, could result in minor or moderate injury.

 **NOTICE**

This warning identifies important messages in this manual, e.g. information on risk for costly damage. Carefully read the message and inform your colleagues.

2 Product Information

2.1 General Description

CPT GEOTECH NOVA is a modularly designed product family for user-friendly, robust and accurate CPT, CPTU, Seismic CPT (SCPT) and Electric Conductivity CPT soil investigations. Please refer to separate documents for descriptions of Seismic and Electronic Conductivity CPT.

The probes are designed for use on land as well as off shore, and give accurate measurements of cone resistance (q_c), sleeve friction (f_s), pore pressure (u) and inclination. Options for sintered pore pressure filters in u_1 and u_2 positions as well as slot filters are available.

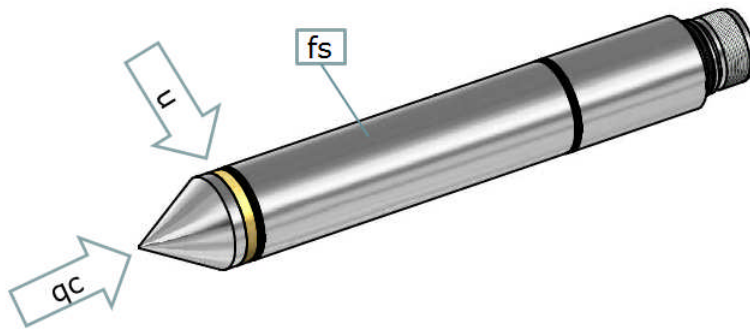

Fig. 1 – The probes are designed for use on land as well as off shore, and give accurate measurements of cone resistance (q_c), sleeve friction (f_s) and pore pressure (u) (figure shows pore pressure filter in standard position “ u_2 ”). In addition there is a built-in inclinometer.

The equipment is available with wireless or cable-based communication from the probe to the surface equipment, facilitating full data transfer and near real-time presentation on the operator’s screen. The equipment is also available in a memory-based offline version with user-friendly data synchronisation.

Geotech started the development of cordless CPT systems in the late seventies and the equipment was made operational in extensive offshore CPT surveys in the Canadian Arctic in the early eighties (Jefferies M.G. and Funegard, E. (1983): Cone penetration testing in the Beaufort Sea. Proc. ASCE Conf. Geotechnical Practice in Offshore Eng., Austin, Tx). The present equipment is a fourth generation and is still today unique on the market.

2.1.1 Acoustic data transfer

The system does not require a cable to transmit measured data, from probe to soil surface. This is done acoustically, i.e. the digitised coded data string is converted into a high frequency acoustic signal. The signal is then transmitted up through the steel of the rods to a microphone on the rig or penetrometer. No cable is used for transmitting the data from probe to the surface. The absence of a cable makes the system very easy and time efficient to use.

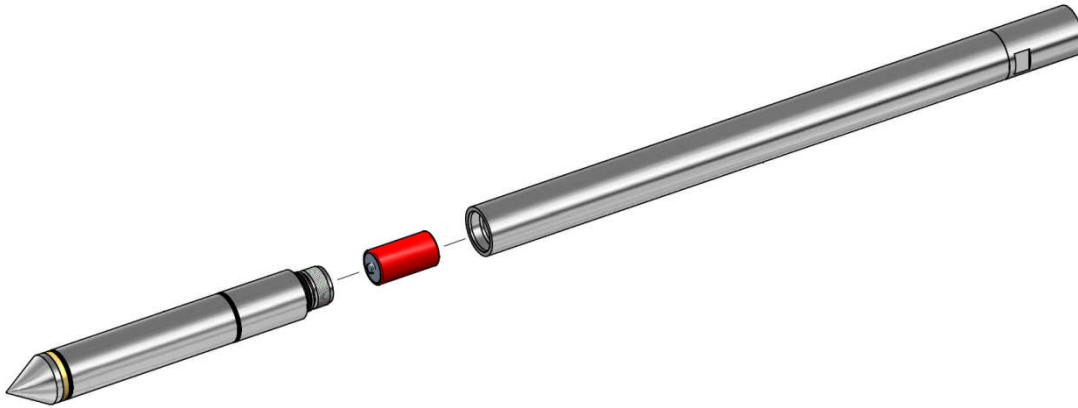

Fig. 2 – The probe and acoustic transmitter assembly is powered by four C size standard batteries. Data are transmitted through the steel of the rod to a microphone on the rig.

From the microphone, the signals are transmitted to the computer interface, which also receives information from the depth encoder. The data is then sent to your laptop PC and presented on the PC screen as curves and digits.

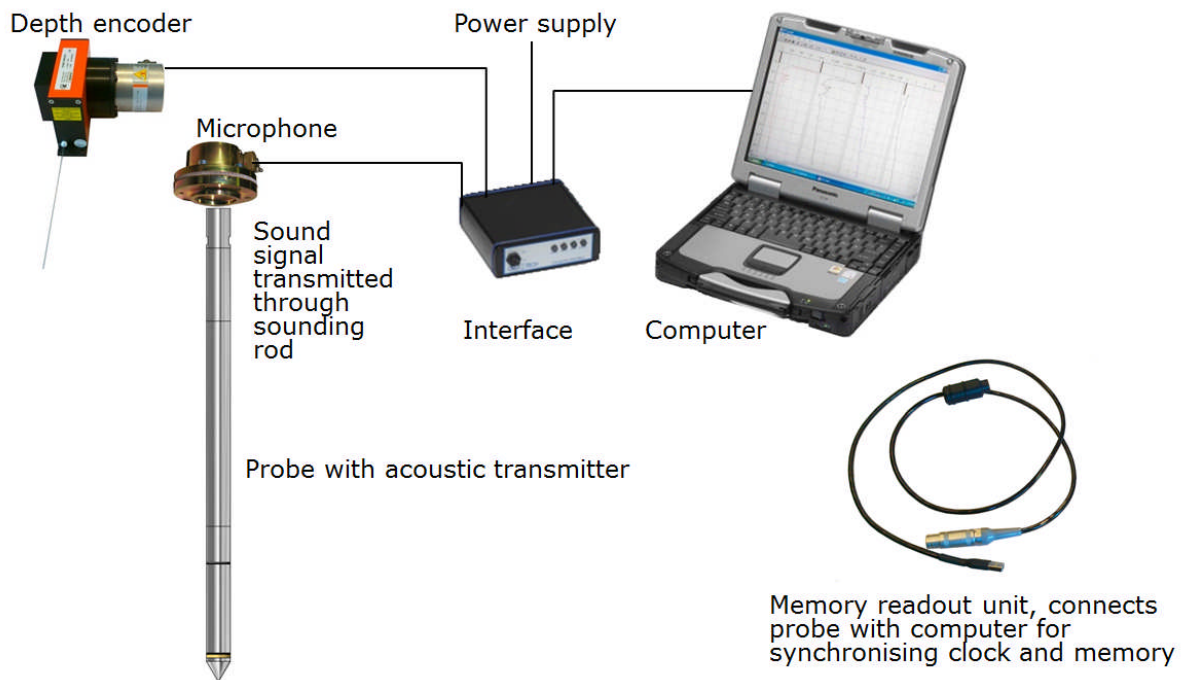

Fig. 3 – Typical system design for a CPT GEOTECH NOVA system with acoustic communication between the probe and the surface equipment. Data from the probe is transmitted through the steel of the rod to the pushing microphone and combined with depth encoder information in the interface that communicates with the logging software in your computer. Test results are presented on the computer screen in near real time.

2.1.2 Radio wave data transfer

The Radio Wave (RW) system does not require a cable to transmit measured data, from probe to soil surface. This is done by means of radio waves, i.e. the digitised coded data string is converted into a high frequency radio signal. The signal is then transmitted up through the hollow rod to a radio receiver typically mounted at the top of the mast of the rig or penetrometer. No cable is used for transmitting the data from probe to the receiver at the surface. The absence of a cable makes the system very easy and time efficient to use.

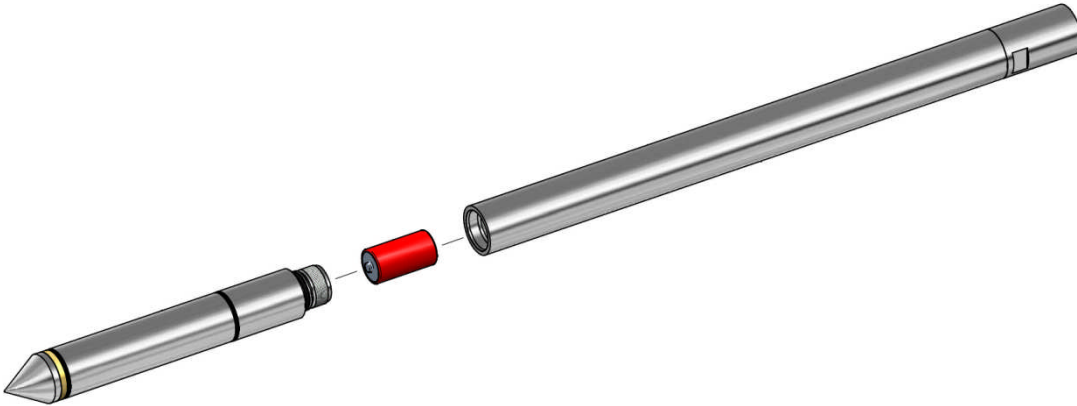

Fig. 4 – The probe and RW transmitter assembly is powered by four C size standard batteries. Data are transmitted through the hollow centre of the rod to a radio receiver on the rig.

From the receiver, the signals are transmitted to the computer interface, which also receives depth information, from a depth encoder. The data is then sent to a laptop PC. The data are presented simultaneously on the PC screen as curves and digits. Note that the interior of the hollow rod should be smooth, dry and clean for best performance.

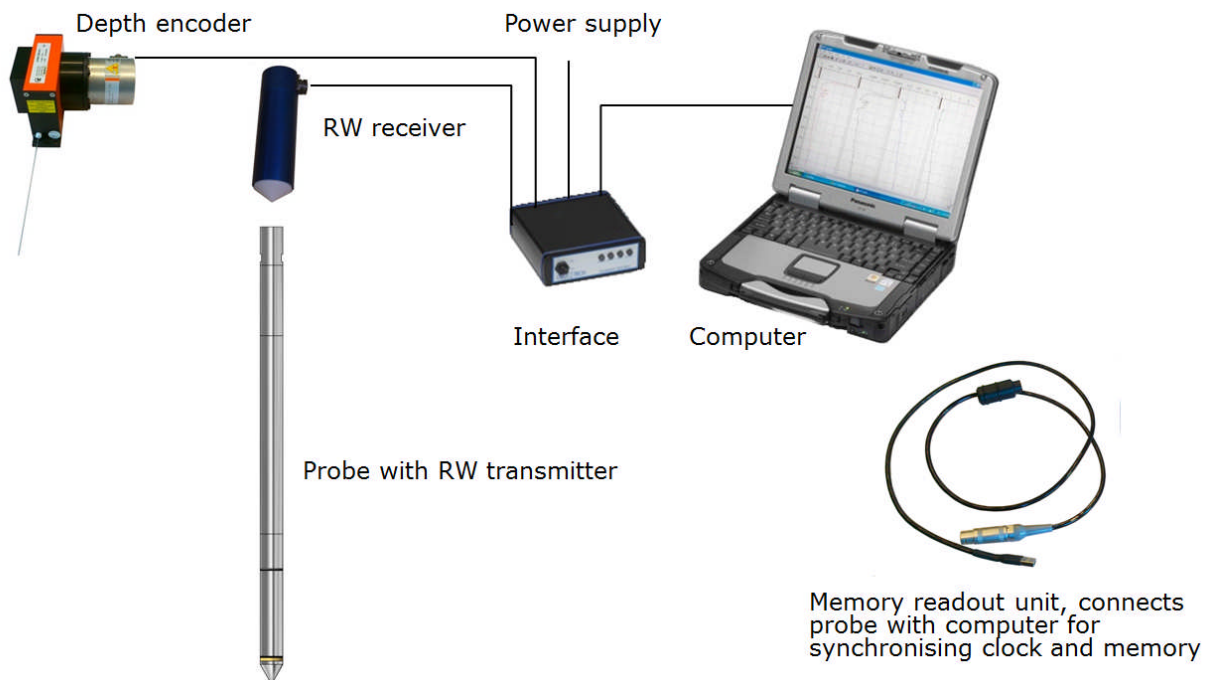

Fig. 5 – Typical system design for a GEOTECH NOVA CPT system with radio wave (RW) communication between the probe and the surface equipment. Data from the probe is transmitted as a microwave signal through the air-filled centre of the rod to the receiver mounted over and in line with the rod string. Data are combined with depth encoder information in the interface that communicates with the logging software in your computer. Test results are presented on the computer screen in near real time.

2.1.3 Probe memory

We recommend the use of probes with back-up memory for additional security in wireless applications. Memory probes can also be used off line when on line data are not required or if a wireless receiver or cable might be hard to apply. A user-friendly USB-based method facilitates synchronisation of the probe and up-loading of saved data. Note that system clocks of probe and logging computer must be synchronised before start of operation.

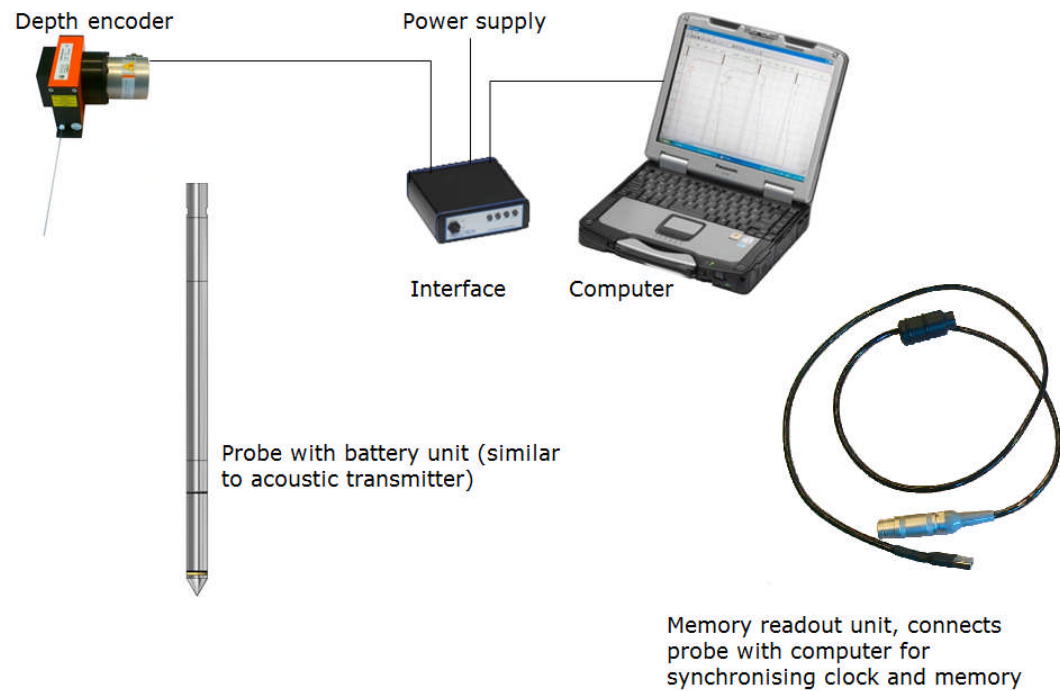

Fig. 6 – Typical system design for a CPT GEOTECH NOVA in an offline application. Data from the sensors are stored in the back-up memory inside the probe. At the same time depth information received via the interface is recorded by the logging computer. After the test you connect the probe to the logging computer and upload the information. The logging software combines depth information with probe data and presents the aggregated result.

2.1.4 Cable data transfer



Fig. 7 – Data are transmitted as a digital signal via a cable and presented near real time on the operator's computer screen.

After processing in the probe, data are transmitted as a digital signal via a cable to the computer interface, which also receives depth information, from a depth encoder. The information is then sent to a laptop PC. The data are presented simultaneously on the PC screen as curves and digits.

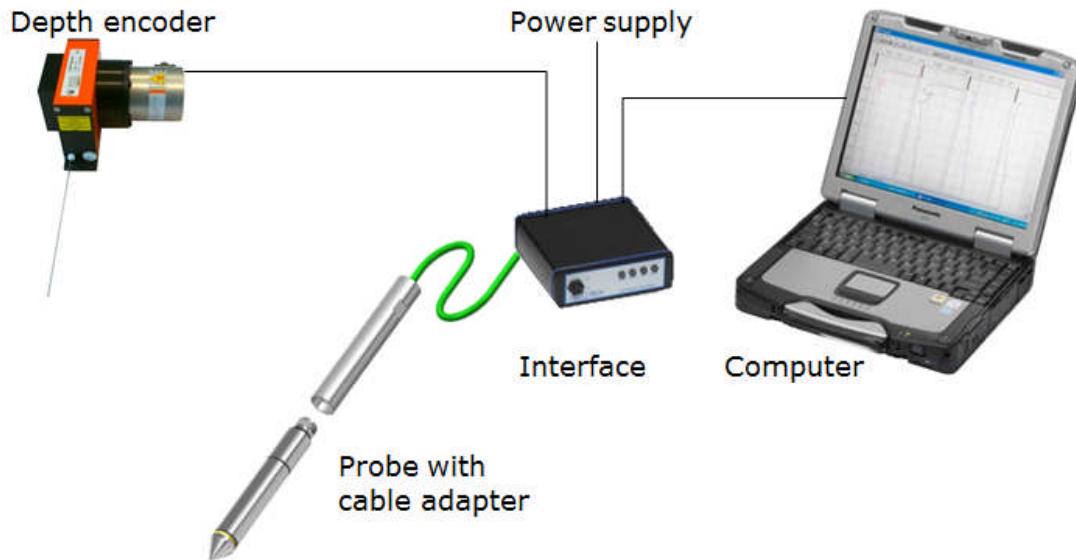
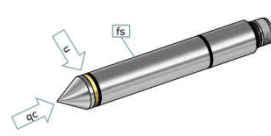

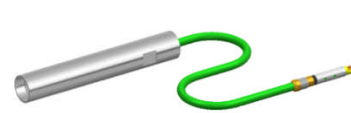





Fig. 8 – Typical system design for a CPT GEOTECH NOVA system with cable communication between the probe and the surface equipment. Data from the probe and the depth encoder are combined in the interface that communicates with the logging software in your computer.







2.2 Intended use









CPT GEOTECH NOVA is designed for geotechnical site investigations, and may only be used for this purpose. All other use is prohibited.



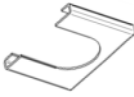





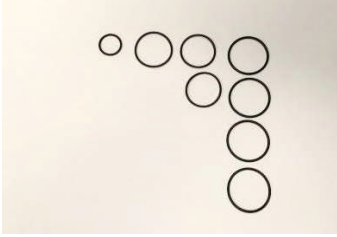

2.3 System components overview





Item No.	Item	Illustration	Description
		NOVA in the hole equipment:	
See separate list	Probe NOVA		Electronic probe for testing soil properties according to the CPT and CPTU methods. Measures soil data while being pushed through the ground, e.g. point resistance (q_c), sleeve friction (f_s) and pore water pressure (u). Diameter 36 mm. Approx. 1.3 kg.
12451	Sound transmitter NOVA		Combined data transmitter and battery compartment to be connected to "probe NOVA". Data is being transmitted as sound signal through the rod. Diameter 36 mm. Conical standard thread. Approx. 2.4 kg.
12445	RW transmitter NOVA		Combined data transmitter and battery compartment to be connected to "probe NOVA". Data is being transmitted as radio signal through the hollow rod. Diameter 36 mm. Conical standard thread. Approx. 2 kg.
10646	Adapter, cable CPT - NOVA		Cable adapter to be connected to "probe NOVA". Power supply and data transmission through the cable. Diameter 36 mm. Conical standard thread. Approx. 1 kg.
10501	Cable, from probe adapter, replaces 10758		Cable, from probe adapter. Green, diameter 10,5 mm. 0.093kg/m. CE conformity according to Low Voltage Directive LVD 2006/95/EC. RoHS. (Connectors 10502 below are mounted on cable pictured).
10502	Set of connectors, probe-cable		Normally mounted on cable at delivery. For connection to the interface via 13173.
10523	Set of connectors, extension		Normally mounted on extension cable at delivery. Optional extension cable to be connected closest to the probe.



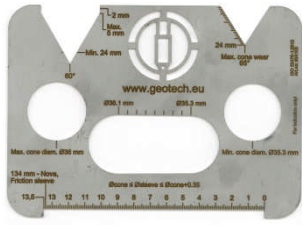

Item No.	Item	Illustration	Description
		NOVA CPTU surface equipment:	
17803	Microphone 10 ton		Microphone for receiving data from the sound transmitter, through the rod. Approx. 3.2 kg.
08875	Microphone 20 ton		Microphone for receiving data from the sound transmitter, through the rod. Approx. 3.2 kg.
41508	Microphone 20 ton, mud		Microphone for receiving data from the sound transmitter. Connection for pumping fluid through the centre of the 36 mm rod. Normally used with 10515 for lubrication of the rod string with bentonite. Approx. 4.9 kg
12450	RW Receiver NOVA		Radio receiver for receiving data through the hollow rod. Diameter 60 mm. Approx. 1 kg.
43065	Cable, receiver-interface box		Cable for connection of the Microphone or RW receiver to the CPT-interface box. 6 m.
13173	Adapter CPT cable-interface		Adapter for connecting probe cable to the interface (for cable CPT only). Approx. 0.15 kg.
10755	Depth encoder (line) 07		Depth encoder to be mounted on the rig. Approx. 1.1 kg.
10757	Cable, depth enc.-interface 07		Cable for connection of the depth encoder to the CPT-interface box. 6m.
70034	CPT-interface box + CPT-log SW		Interface for CPT data collection and connection to logging computer. (Includes also CPT-LOG) Logging computer not included. Approx. 1.2 kg.

Item No.	Item	Illustration	Description
08871 (included in 70034 above)	CPT-LOG		CPT logging software. Right to use on one computer, licensed by owner of all rights, Ingenjörfirman Geotech AB.
10661	Memory read out unit NOVA		Connect the Memory read out unit to the "probe NOVA" (use magnet for removing protection plug) and to the USB connection of your computer. Used for synchronising clocks and uploading data.
06975	Cable, serial, interface-PC		Cable for connection of laptop computer to the CPT-interface box.
27886	USB – Serial adapter		For use with computer that is not equipped with RS232 serial port. Note that special settings might be required, depending on computer type and op. system version.
41540	Cable, power interface, 12 Vdc		Cable for connection of 12V power supply to the CPT interface.
10609	Power supply adapter for interface 230V AC		Cable for connection of 230V AC power supply to the CPT interface.
NOVA boxes and cases			
10785	Transport case NOVA system		<p>Double transport box (black type) for the safe transport of instruments. Complete: 60 x 24 x 48 cm. Approx. 12.1 kg.</p> <p>Upper case for NOVA probe and other "in the hole" equipment: 60 x 24 x 19 cm.</p> <p>Lower case for interface, cables etcetera: 60 x 24 x 29 cm.</p>

Item No.	Item	Illustration	Description
17876	Transport case NOVA ply		Transport box (wood coloured plywood type) for "probe NOVA" and transmitter. Packing material for the safe transport of instruments. 55 x 15 x 12 cm. Approx. 2.3 kg.
		Mounting details (optional)	
09621	Microphone holder		Microphone holder to be screwed onto the pushing microphone. Approx. 1.35 kg.
13828	Pushing adapter		Pushing adapter for cable or radio CPT. Approx. 1.45 kg.
17049	Bracket for microphone holder		Bracket for microphone holder or pushing adapter to be welded on the penetrometer.
		NOVA CPTU spare parts and consumables	
18907	Point, hardened steel, NOVA		Point, hardened steel. Diameter 36 mm. Approx. 0.17 kg. Spare part to probe NOVA (consumable).
16671	Friction sleeve, NOVA		Friction sleeve, steel. Diameter 36 mm. Approx. 0.24 kg. Spare part to probe NOVA (consumable).
41310	Filter ring, brass		Filter ring, brass. Diameter 36 mm. 0.12 kg Spare parts to probe NOVA (consumables).
17835	Saturated filter rings, 12 pcs de-aired and packed in glycerine		Filter rings, brass, set of 12 packed in glycerine. Diameter 36 mm. Spare parts to probe NOVA (consumables).
12429	Support ring for X ring, NOVA		Support ring, steel. Spare part to probe NOVA.
41380	X ring		X-ring, rubber. Diameter 36 mm. Approx. 0.006 kg. Spare parts to probe NOVA (consumables).

Item No.	Item	Illustration	Description
10702	Spare set O rings NOVA		O-rings set of 8 in mixed sizes, e.g. for protecting against water intrusion: 13578 1pc 10827 1pc 13573 2pcs 13576 4pcs Rubber. Approx. 0.002 kg. Spare parts to probe NOVA (consumables).
13579	O ring, Nova end piece		O ring, Nova end piece connection to transmitter.
17858	CPT vaselin		Vaselin - refined petroleum product for lubrication of probe NOVA (consumable).
Parts sold separately	Point assembly for "u ₁ " pore pressure measurement.		More information available on request.
17296	Slot filter NOVA		Steel ring. Diameter 36mm. Replaces filter ring in soils with high negative pore pressure (consumable). 0.018kg.
21512	CPT grease		Grease for slot filter (consumable). 200 g.
21531	CPT oil		Oil for slot filter (consumable). 200 g.
08598	Seal for mud microphone.		Spare part for 41508 Microphone 20 tons, mud.
10596	Spare HASP key		USB key for hardware lock (Spare part, not additional license).
Tools etc.			
26052	Tool, support ring 10 cm2		Tool for removing support ring from friction sleeve. 16g.

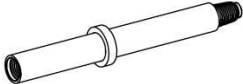
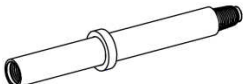
Item No.	Item	Illustration	Description
19675	Brush, plastic for probe.		Brush for cleaning CPT probe.
24103	Wear template		Template for checking dimensions and wear of probe.
08531	User's manual		User's manual, printed version.
CPT rods			
07629	CPT sounding rod 36 STD		CPT sounding rod for soil investigation. For cable or acoustic data transfer. Properties of each part: Diameter: 36 mm, conical STD "Standard" thread. Active length: 1000 mm Total length: 1040 mm incl. winding Approx. weight: 6.75 kg
16976	CPT sounding rod 36 STD stainless steel lining for RW data transfer		CPT sounding rod for soil investigation. For RW data transfer. Not suitable for cable. Properties of each part: Diameter: 36 mm, conical STD "Standard" thread. Active length: 1000 mm Total length: 1040 mm incl. winding Approx. weight: 7 kg

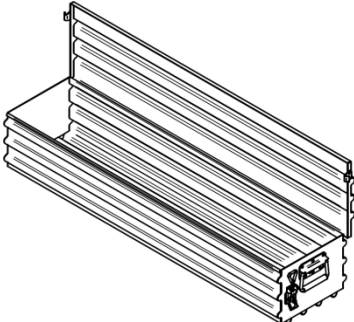
Item No.	Item	Illustration	Description
01826	CPT sounding rod 36 "Speedlock" (SPL)		CPT sounding rod for soil investigation. For cable or acoustic data transfer. Properties of each part: Diameter: 36 mm, conical SPL thread. "Speedlock". Active length: 1000mm Total length:1040 mm incl. winding Approx. weight: 6.75 kg
10515	CPT rod for bentonite		CPT sounding rod with check valve and nozzles for lubrication of the rod string with bentonite. Use together with "41508 Microphone, mud". Rod diameter: 36 mm, ring diameter: 40 mm), Conical STD "Standard" thread. Active length: 1000 mm Total length: 1040 mm incl. winding. Approx. weight: 6.8 kg.
12418	Friction reducer STD/STD ring		To be mounted before the first rod. Reduces the friction between soil and rod. 36mm STD/STD threads.
12419	Friction reducer STD/SPL ring		To be mounted before the first rod. Reduces the friction between soil and rod. 36mm STD/SPL threads.
02846	Scraper rubber		Cleans the rod while pulling it up.
24835	Transport case for rods		Transport case for 1 m rods. Dimensions: 113 x 27 x 22 cm. Weight 19.3 kg

The CPT GEOTECH NOVA product family is being continuously developed and improved. We therefore reserve the right to changes of the information above.

2.4 CPTU probe

The probes are designed for use on land as well as off shore, and give accurate measurements of cone resistance (q_c), sleeve friction (f_s) and pore pressure (u). Options for sintered pore pressure filters in u_1 and u_2 positions as well as slot filters are available.

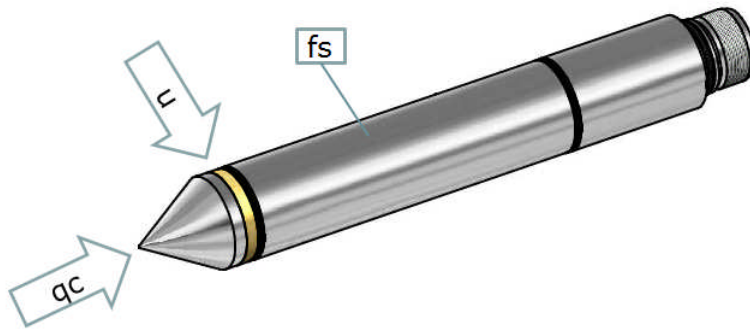

Fig. 9 –The probes are designed for use on land as well as off shore, and give accurate measurements of cone resistance (q_c), sleeve friction (f_s) and pore pressure (u) (figure shows pore pressure filter in standard position “u2”). In addition there is a built-in inclinometer.

The equipment is available with wireless or cable-based communication from the probe to the surface equipment, facilitating full data transfer and near real-time presentation on the operator’s screen. The equipment is also available in a memory-based offline version with user-friendly data synchronisation.

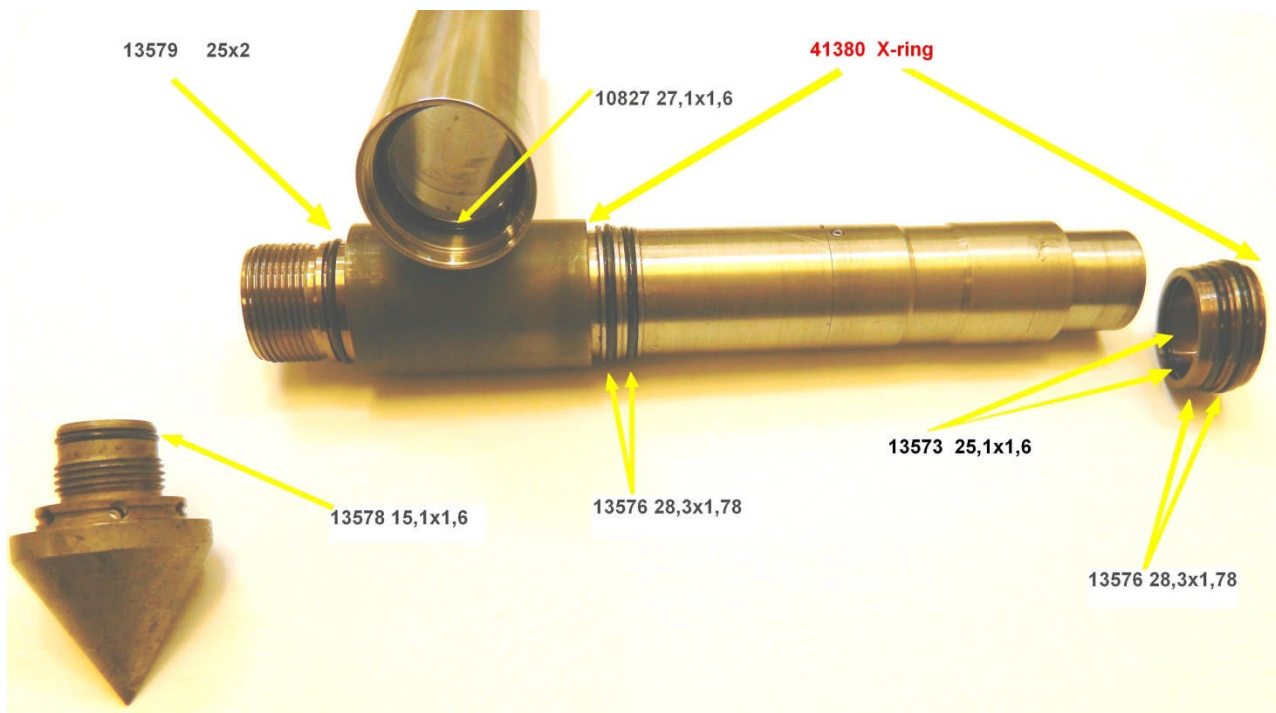

Fig. 10 – Sealing rings of the CPT GEOTECH NOVA probe.

The probe has a number of rubber rings for preventing water and soil intrusion. Rubber ring 10827 is used for pre-tensioning the friction sleeve.

2.4.1 Back-up memory

Probes intended for off-line use, are equipped with a built in memory. Back-up memory is also recommended for use in applications with real time wireless data transfer. Data packages are identified with time stamps. When the memory is full, the oldest data are overwritten (standard configuration).

2.5 Transmitters and adapters

For power supply and communication, one of the following alternatives should be selected. Please refer to separate documents for information on adapters for special purposes, e.g. for Seismic CPT (SCPT) and for measuring electric conductivity.

2.5.1 Acoustic transmitter

The combined data transmitter and battery compartment is intended for use together with "probe NOVA" with back-up memory. Data is being transmitted as sound signal through the rod to a receiver microphone mounted on the yoke of the pushing rig. Diameter 36 mm. Conical standard CPT thread. Batteries: 4 pcs "C" size alkaline.

2.5.2 Radio transmitter

The combined data transmitter and battery compartment is intended for use with "probe NOVA" with back-up memory. Data is being transmitted as radio waves through the hollow centre of the rod to a receiver mounted on the pushing rig in line with the rod. Diameter 36 mm. Conical standard CPT thread. Batteries: 4 pcs "C" size alkaline.

2.5.3 Cable adapter

The cable adapter is intended for use together with "probe NOVA". The probe communicates and gets power supply through the cable. Diameter 36 mm. Conical standard thread.

2.6 Surface equipment

2.6.1 Acoustic receiver microphone

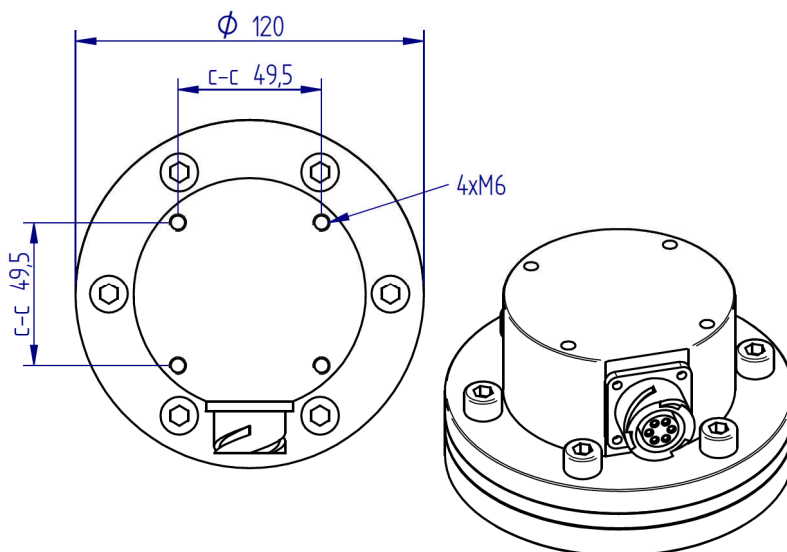

Fig. 11 – Acoustic receiver microphone.

The microphone is attached to the pushing yoke of your rig or penetrometer. It is used for pushing the rod, at the same time receiving the signal from the down-hole acoustic transmitter. There are 4 threaded holes, (4 x M6) for mounting, on top of the microphone.

Please refer to separate documents for description of optional mounting details, subsea receiver microphones etc.

2.6.2 RW receiver

The RW receiver picks up the signal from the down-hole RW transmitter. Data is being transmitted as radio waves through the hollow centre of the rod to the receiver, typically mounted on the pushing rig in line with the rod. Diameter: 60 mm.

2.6.3 Receiver cable pin configurations

Interface connector pins	Function	Acoustic Receiver Microphone	RW Receiver	Cable
A	Power out		A	
B	Cable signal			B
C	-			
D	Ground	D	D	D
E	Wireless signal	E	E	
F	-			

2.6.4 Adapter CPT cable-interface

Adapter for connecting probe cable to the interface (for cable CPT only):



Fig. 12 – Adapter for connection of cable from the probe to the interface.

2.6.5 Depth encoder

Interface pin configuration	Cable 10757	Function
A	-	
B	Green	Pulse
C	Grey	Pulse 90 deg.
D	-	
E	Brown	Plus
F	White	Minus



Fig. 13 – Depth encoder

The depth encoder 10755 is pre-set to give increasing depth when the wire is going inwards. If you desire the reverse (increasing depth when the wire is pulled out) you swap the wires on pin B and pin C in the cable connector that is connected to the interface. The depth encoder should be mounted with the wire entrance facing downwards, to minimise water intrusion.

Please refer to separate documents for information on other depth encoder types.

2.6.6 Computer interface



Fig. 14 – Computer interface – front panel

The interface receives and processes the signal from the depth encoder in real time, based on pre-set properties, e.g. depth encoder resolution, pushing method and rod length. It also receives real-time sensor data from the probe. Depth information and sensor readings are aggregated and passed on to the logging computer.

The built-in overload relay can be used for external alarm, or for automatically stopping the penetrometer. The CPT operator can pre-set a maximum point resistance (q_c) and/or tilt increment at which the cone penetration will automatically be halted, in order to avoid damaging the probe. This can occur if the probe hits a stone or gravel or slants on its side. In particular, bending of probes can occur within a few centimetres slanted pushing. Note that special equipment will be required for this function (not included in standard delivery).

The front panel of the interface has a power switch and four lamps, indicating probe signal strength, depth encoder pulses, data communication with the computer and power.



Fig. 15 – Computer interface – back panel

The back panel of the standard CPT interface has four different connectors, each only fitting one of the four corresponding cables that come with the system:

- Sensor data from the probe (via microphone, RW receiver or cable).
- Signal from the depth encoder.
- RS232 data communication with the logging computer.
- Power supply: 12 – 15 V.

Serial connector pin configuration

Interface	RS232	D-sub
A		3
B		2
C		-
D		5

Power connector pin configuration

Interface	Function	Standard cable
A	Overload relay (common)	-
B	Overload relay (norm open)	-
C		-
D	Power supply	Plus (red)
E	Power supply	Minus (black)
F	Overload relay (norm closed)	-

Special power cable with overload relay output available on request.

Refer to separate documents for information on the multi-purpose rig interface, normally delivered pre-installed on Geotech site investigation rigs, and other special type interfaces.

2.6.7 CPT-LOG software



Fig. 16 – CPT-LOG logging software for installation on the operator’s computer. The HASP key (right) is required for use of the software when not connected to the interface. Medium for software is subject to change without notice (e.g. disc, memory stick or download).

The interface interacts with the CPT-LOG software, installed on the logging computer. The software has functions for setting up the interface, administrating probes, handling probe backup memories, performing tests and presenting test results.

The HASP key that comes with the system is required for running the software when not connected to the interface.

Please refer to separate manual for detailed information on the CPT-LOG software.

2.6.8 Memory read out unit NOVA



Fig. 17 – Memory readout unit to be connected to the probe and USB outlet of the logging computer.

The memory read out unit is used for synchronising the logging computer with probes that have built-in memory, and uploading stored data. The memory read-out unit is connected to the memory probe and a USB outlet of the logging computer.

2.7 SCPT equipment

Please refer to separate document for description of additional equipment for Seismic CPT.

2.8 Equipment for measuring electric conductivity

Please refer to separate document for description of additional equipment for in situ measurement of electric conductivity/resistivity.

3 Preparations

3.1 Preparing the NOVA CPTU Probe

3.1.1 Preparing the NOVA CPTU Probe (standard configuration)

Below you will find a check list for the preparations of the probe before a typical CPTU test. Please refer to the "Installation" chapter and separate software manual for information about setting up the surface equipment. Note that details may change depending on soil conditions, applicable standards and end customer demands.

1. Check tip and friction sleeve for damages. Damaged parts should be replaced. Check threads for dirt and corrosion.
2. Make sure that the probe has a valid calibration certificate and that the "Cone Database" of the logging computer is updated with correct numbers. Refer to CPT-LOG software manual.
3. Note that memory probes, used in wireless configurations, must be synchronized with the logging computer before start of operation. Refer to instructions below and CPT-LOG software manual.
4. Keep the probe stored in a dry place at a temperature as close to the ground temperature as possible (normally approx. +5°C). The probes are equipped with a system to compensate for temperature variations. Nonetheless, fast temperature changes might affect the accuracy of the sounding results. Thermostat-controlled storage boxes are available on request.
5. Make sure that you have saturated filter rings and enough glycerine for de-airing of tip and pore pressure chamber, that all sealing rings are intact, and that the probe is clean and lubricated with a little vaselin. Check the threaded part and the central connector of the end piece for dirt and corrosion. Please refer to separate instructions if you are using slot filters or other de-airing media.



Fig. 18 – Use glycerine and saturated filter rings for de-airing the CPT GEOTECH NOVA probe

6. Fill the pore pressure chamber with glycerine and make sure to remove all bubbles:



7. Place a saturated filter ring on the probe. Top up with glycerine if necessary:



8. Mount the tip. The glycerine will be pressed into the tip and effectively fill the cavities.



9. Pre-stress the friction sleeve by tightening the cone tip by hand. When mounting the tip a small over-pressure may build up inside the pressure chamber – therefore you should allow the probe to rest for a while before performing zero test.



Fig. 19 – De-airing of CPT GEOTECH NOVA probe

- Put the probe in a bucket or similar with water, just covering the filter ring. In some cases a rubber membrane protection is preferred. Note that no water should be allowed to enter through the contact piece. In order to protect the contact piece from water ingress, you might already now like to mount the eligible cable adapter, wireless data transmitter or adapter with special functionality.



Fig. 20 – Keep the filter of the de-aired probe under water. Note the contact piece may not be exposed to water.

- Perform the test as described below.

NOTICE

No water is allowed in this part of the probe:



3.1.2 Filter ring in u_1 position (option for special purposes)

Preparations

1. Make sure that the filter ring is completely saturated.
2. Fill the pressure chamber with glycerin.
3. Assemble the tip components and screw the tip onto the probe.

Also refer to instructions for standard probe configuration above.

3.1.3 Slot filter (option for special purposes)

Preparations

1. Fill the cavities of the tip and the slot with CPT grease.
2. Fill the pressure chamber with CPT oil.
3. Screw the tip onto the probe.

Also refer to instructions for standard probe configuration above.

3.1.4 Saturation of filter rings

Filter rings, saturated from the factory

Geotech offers a set of 12 filter rings, de-aired from the factory and conveniently packed in a jar with glycerine. The rings have been vacuum treated and are well saturated.



Fig. 21 – Set of 12 saturated filter rings conveniently packed in a jar with glycerine from the factory.

Vacuum treatment

Put the filter rings in the tank of the vacuum pump. Fill the tank with glycerine so that the content is covered. Connect the pump and de-air for about one hour. Be observant so no glycerine is sucked into the pump. This could damage the pump. Keep the filters in the liquid until immediately before use..

3.1.5 Registering a new calibration certificate

Before you start using a new or recently calibrated probe with the system, you will need to enter calibration data in the “Cone Database” of CPT-LOG. Make sure to enter the right numbers in the right places. Please refer to the CPT-LOG manual for detailed instructions on software features:

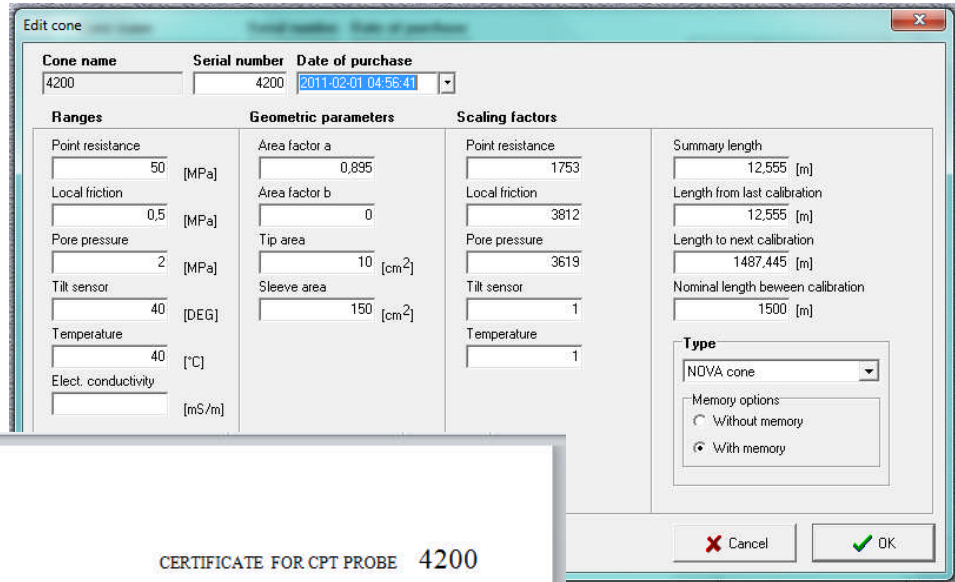

CERTIFICATE FOR CPT PROBE 4200

Probe No 4200
 Date of Calibration 20110201
 Replacement of
 Calibrated by Stefan Josefsson
 File name 4200 20110201 111218.doc

Point Resistance

Maximum Load	50	MPa	
Range	50	Mpa	
Scaling Factor	1753		
Resolution	0.4352	kPa	(18 bit resolution)
Area factor (a)	0.895		

ERRORS
 Max. Temperature effect when not loaded 27.4176 kPa
 Temperature range 0-40 deg. Celsius.

Local Friction

Maximum Load	0.5	MPa	
Range	0.5	Mpa	
Scaling Factor	3812		
Resolution	0.0100	kPa	(18 bit resolution)
Area factor (b)	0.000		

ERRORS
 Max. Temperature effect when not loaded 0.7500 kPa
 Temperature range 0-40 deg. Celsius.

Pore Pressure

Maximum Load	2	MPa	
Range	2	Mpa	
Scaling Factor	3619		
Resolution	0.0211	kPa	(18 bit resolution)

ERRORS
 Max. Temperature effect when not loaded 0.6119 kPa
 Temperature range 0-40 deg. Celsius.

Tilt Angle 0-40 Deg.

Temperatur gauge 0-40 Cel. Scaling Factor 1

Back-up memory

-----for demo purposes only-----

3.1.6 Synchronisation of the memory probe before test

Memory probes, used in wireless configurations, must be synchronized with the logging computer before start of operation. Please refer to the CPT-LOG manual for detailed instructions on software features.

1. Remove the plug from the end piece of the probe, using the magnet that is attached to the memory read-out unit. Connect the round connector to the probe and the other end of the cable to your logging computer:



Fig. 22 – Synchronisation of the memory probe before test.

2. Perform synchronization as described in the CPT-LOG software manual.
3. Remove the cable from the probe and replace the plug in the end piece.

3.2 Preparation of wireless probe assembly

1. Check that probe and transmitter are clean and free from corrosion. Pay special attention to the threads of the probe and corresponding internal threads of the transmitter. Dirty or corroded threads might cause voltage drop affecting the functionality of the system.
2. Make sure that the probe has been synchronized with the logging computer. Prepare the probe as described above.
3. Switch on the interface, start the software and enter properties. For details, please refer instructions below and to the CPT-LOG software manual.
4. Put four fresh "C size" alkaline batteries in the battery compartment of the transmitter, the positive pole facing the probe. Mount the probe on the sound transmitter. Tighten by hand firmly but not too hard.

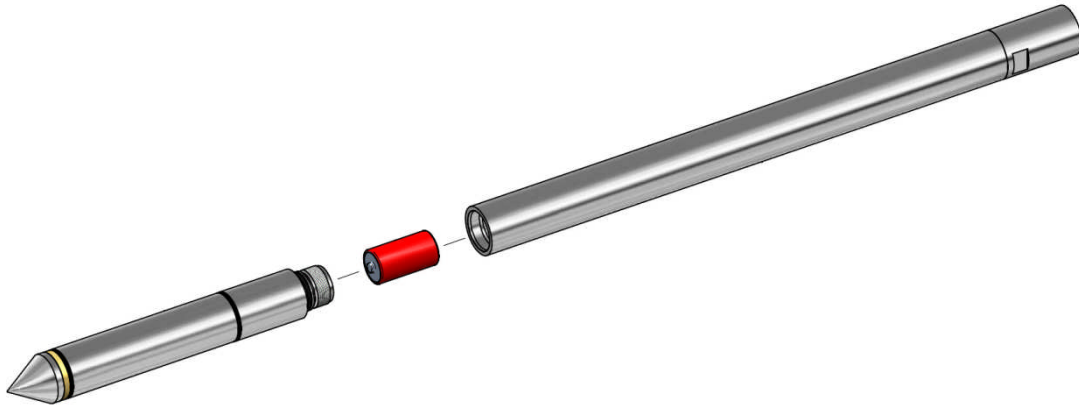

Fig. 23 – Put four fresh "C size" alkaline batteries in the battery compartment

5. Perform zero reading and start the test. For details, please refer instructions below and to the CPT-LOG software manual.

3.3 Preparation of cable probe assembly

1. Check that probe and cable adapter are clean and free from corrosion. Pay special attention to the threads of the probe and corresponding internal threads of the adapter. Dirty or corroded threads might cause voltage drop affecting the functionality of the system.
2. Mount the probe on the adapter. Tighten by hand firmly but not too hard.



Fig. 24 – The standard cable probe assembly

3. Roll out the cable and thread it through the rods. Use the cap to protect the cable contact. Make sure that there are no sharp edges that may damage the cable.

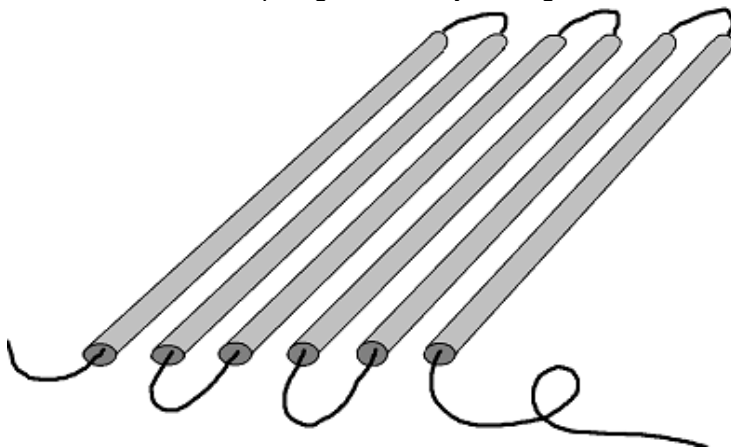

Fig. 25 – Cable threaded through the rod segments

4. Connect the cable to the interface and the probe assembly.
5. Perform zero reading and start the test. For details, please refer to instructions below and the CPT-LOG software manual.

4 Performing a test

4.1 Pre-drilling

Depending on soil conditions, type of de-airing medium and local quality requirements for pore pressure measurements, pre-drilling may be necessary.

If the first meters consist of dry crust with clay or silt, pre-drilling typically is made down to 0.5 – 1.0 m.

If the first meters consist of fillings, pre-drilling is recommendable through the whole filling. If the soil seems to collapse into the hole it should be stabilized with a casing pipe or a fluid, e.g. bentonite. If casing is being used, it should be filled with water.

If ground frost is present, pre-drilling should always be carried out. If the probe is pressed through frozen soil, a negative pressure might occur, sucking the de-airing medium out of the filter.

4.2 Anchoring

The pushing unit, e.g. penetrometer or site investigation rig, should be anchored to the ground if its weight is lower than the expected pushing force.

Different augers may be used for different types of soils. If the soil surface consists of soft clay or mainly soft clay, anchoring augers with large diameters might be required. Suitable diameters are normally between 100 mm and 200 mm. For soft clays, augers with diameters up to 400mm are available. If the soil surface consists of non-cohesive soils, augers with a smaller diameter could be sufficient, but may need to be driven deeper layer using extension rods. Please contact us for a proposal.

If the torque needed to drive the augers is very high, it could help to lubricate the augers e.g. with bentonite.

4.3 Performing a CPTU test

Note that software commands might vary depending on version installed. For details please refer to the corresponding CPT-LOG manual.

1. Set up the software and register the probe as described in the CPT-LOG software manual. Prepare the equipment as described above.
2. Switch on the interface, start CPT-LOG and select "Penetration".
3. Press View (F5) – Select 4 windows in Graph, e.g. Point resistance, Local friction, Pore pressure and Tilt angle. Press OK.
4. Select Options>Units from the drop-down menu. Set units for point resistance – MPa; friction – kPa; pore pressure – kPa; dissipation – kPa.
5. Press New (F1).
6. Synchronise your memory probe every day. Connect the probe to the computer, using the memory read-out unit. Select Options">"Cone synchronization.
7. Select probe under "Probe name". Check scaling- and area factors against the calibration certificate.

8. Select transmission method (Wireless, Cable or Memory only).
9. If the optional "Total force" function is to be used, press "Advanced" and check "Enable total force logging". Check/set force sensor scaling factor. Press OK. Note that this option is only available for systems pre-installed on Geotech site investigation rigs.
10. Press OK.
11. Fill in proper values in the "Test info" window. Under Alarms, we recommend you to set the value 50.00 for "Tilt angle derivate", press OK.
12. The first time you run the program, you should create a folder with, for instance, the name "CPT data" for saving the cpt files. State a file name, press Save.
13. When the "Confirm" box is opened:
 - a. For "Acoustic" system: Put four fresh "C size" alkaline batteries in the battery compartment of the transmitter, the positive pole facing the probe. Mount the probe on the sound transmitter. Tighten by hand and not too hard. Press OK. Hold the sound transmitter, with unloaded probe, against the receiver and conduct zero reading. Wait until all channels work properly, press OK.
 - b. For "RW" system: Put four fresh "C size" alkaline batteries in the battery compartment of the transmitter, the positive pole facing the probe. Mount the probe on the RW transmitter, press OK. Direct the free end of the transmitter towards the receiver, with unloaded probe, conduct zero reading. Wait until all channels work properly, press OK.
 - c. For "Cable" system: Make sure that the cable and adapters are well connected (check all connections between probe and interface). Press OK and conduct zero reading with unloaded probe. Wait until all channels work properly, press OK.
 - d. For "Memory only" system. Put four fresh "C size" alkaline batteries in the battery compartment. Press OK and conduct zero reading with unloaded probe. Press OK.

Note! Classic acoustic probes must be pressed against the receiver within 30 seconds after sound transmitting has started. This limitation does not apply to the NOVA probe.
14. Make sure that the zero read window has closed, before you put any load on the probe.
15. Mount the first rod segment. Hold the rod/probe assembly in starting position and adjust the yoke so it is ready for start of test. Acoustic system: the microphone to be in contact with the rod.
16. Press Start (F2) and start the test. Ensure that the pushing speed is 2 cm/second, adjust if necessary (refer to the manual for your rig or penetrometer).
17. Continue pushing and lengthening the rod to the desired depth or until you reach a layer that cannot be penetrated, with optional pauses for dissipation tests (see below). Note that you normally do not need to press "pause" when lengthening the rod.
18. To end the test, or to pause, press Pause (F3)
19. Press either Start (F2) to continue test, or pull up rods and probe and press Stop (F4).
20. If you want to end the test, press "Yes" to answer the question: Do you confirm?
21. Select proper stop code. Stop codes 96-99 give unspecified causes. Press OK. You may add your own codes; select "Options" > "End test code descriptions".

22. Unload the probe and press OK to conduct zero reading. Check that the difference values are stable and preferably low. A high value could indicate that the probe has been damaged or that soil residues obstruct the free movements of the friction sleeve.

23. When zero reading is done, press OK. Wait until the zero reading window closes.

4.4 Dissipation test

During the penetration an excess pore pressure is generated around the probe. During a pause in penetration the pressure will start to dissipate. The rate of dissipation can give valuable information about soil characteristics. During a normal test as described above:

- a. Stop pushing, and immediately click “Dissipation Start”.
- b. Wait until the pressure has stabilised without moving the equipment. Special criteria may apply for minimum duration of the dissipation test.
- c. Click “Dissipation Stop” and continue the CPTU test.

For details please refer to the corresponding CPT-LOG manual.

5 After test

5.1 Immediate actions

After the test, it is very important to clean the probe and to make sure that all sealing rings are intact. Remaining dirt could affect test results. X-rings and O-rings that are damaged or of wrong type could in addition cause water and soil intrusion, in worst case damaging the sensitive electronics. Wipe dry the equipment and store it in a controlled environment with low humidity between jobs.

WARNING

Deep-sea probe assemblies that have been exposed to high pressure should be opened with great care. Under certain conditions considerable energy in the form of overpressure could accumulate.

1. Clean and wipe dry the probe assembly directly after test and before disassembling.
2. Disassemble the probe from the transmitter or adapter. Inspect the O-ring for damages and confirm that the internal parts of the joint are dry. If any water should be detected, the equipment must not be used until the root-cause has been identified and eliminated, all parts of the equipment are completely dry, and the functionality has been tested.
3. If necessary clean the internal threads of the transmitter (adapter). Dirty or corroded threads might cause voltage drop affecting the functionality of the system. If necessary use a rotating wire brush to clean the thread of the transmitter.

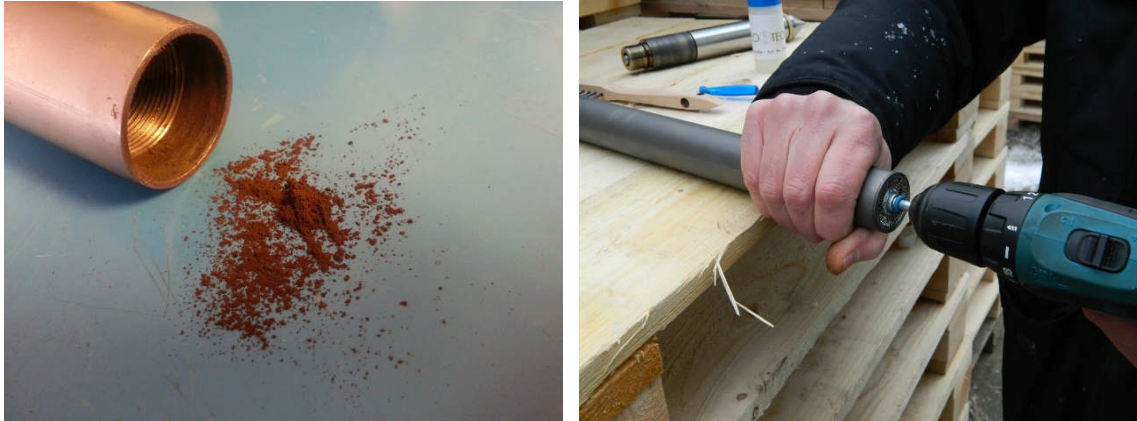

Fig. 26 – Dirty or corroded threads might affect the functionality of the system. If necessary use a rotating wire brush to clean the thread of the transmitter.

3. Dismount the point and check for damages. Clean cavities and threads and wipe dry.
4. Remove the filter ring from the probe. Under certain conditions the filter ring can be re-used; however the general recommendation is to replace it. Store the filter ring in a jar of glycerine or water if you intend to use it again (dry soil residues could clog the filter permanently). Empty the pressure chamber and wipe dry the probe.
5. Dismount the friction sleeve by careful rotation and pull it off. Check that the measuring body is dry under the friction sleeve. Water under the friction sleeve indicates that friction sleeve O-rings should be replaced.
6. Use the optional tool (26052) for removing the support ring from the friction sleeve: a) Put the tool on top of the measuring body (refer to picture below), b) Put the friction sleeve back on the measuring body and press down until the support ring comes out at the top. To avoid hand injury: Hold the friction sleeve and the end piece – not the measuring body. Make sure not to lose the pre-tensioning O-ring.

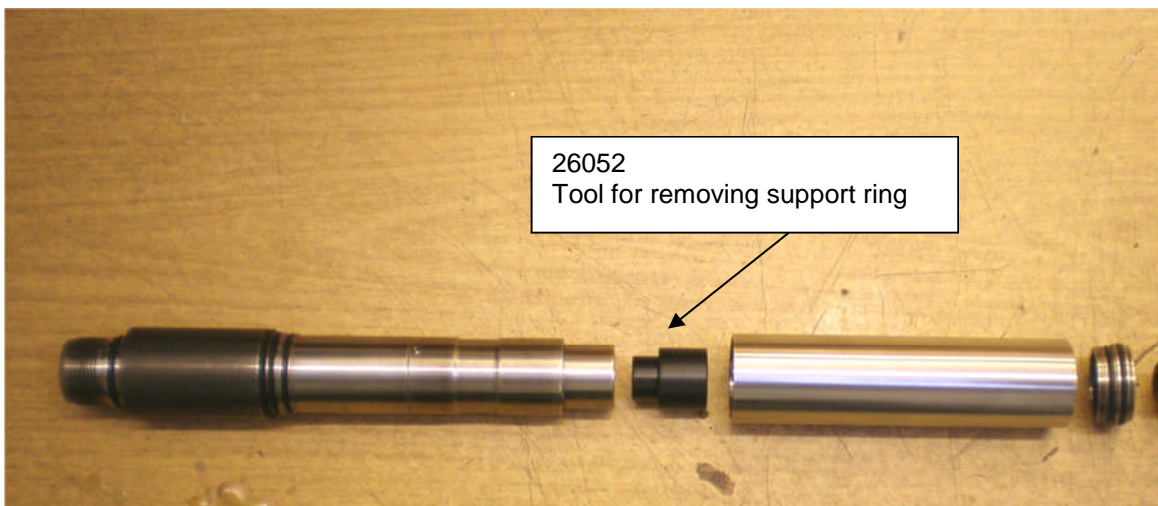

Fig. 27 – Using tool No. 26052 for removing the support ring.

! CAUTION

To avoid hand injury when removing the support ring using tool No. 26052: Hold the friction sleeve and the end piece – not the measuring body.

- Clean the friction sleeve in both ends and check for damage.



Fig. 28 – Cleaning the friction sleeve.

- Remove the sealing rings from the measuring body. Clean the measuring body as well as the sealing rings and wipe dry.



Fig. 29 – You may use water when cleaning the measuring body – but protect the contact area of the end piece from moist and water.

- If necessary clean the external threads of the probe.



Fig. 30 – Cleaning the threads of the probe's en piece. Protect the contact area of the end piece from moist and water.

10. Remove the sealing rings from the support ring. There are two O-rings and one X-ring on the support ring, and two O-rings inside. Clean the support ring as well as the sealing rings and wipe dry.
11. Inspect the sealing rings for possible damages and pay extra attention to the grooves of the X-rings for possible soil residues. Soil residues in the X-ring grooves could affect test results. Damaged sealing rings may result in leakages.

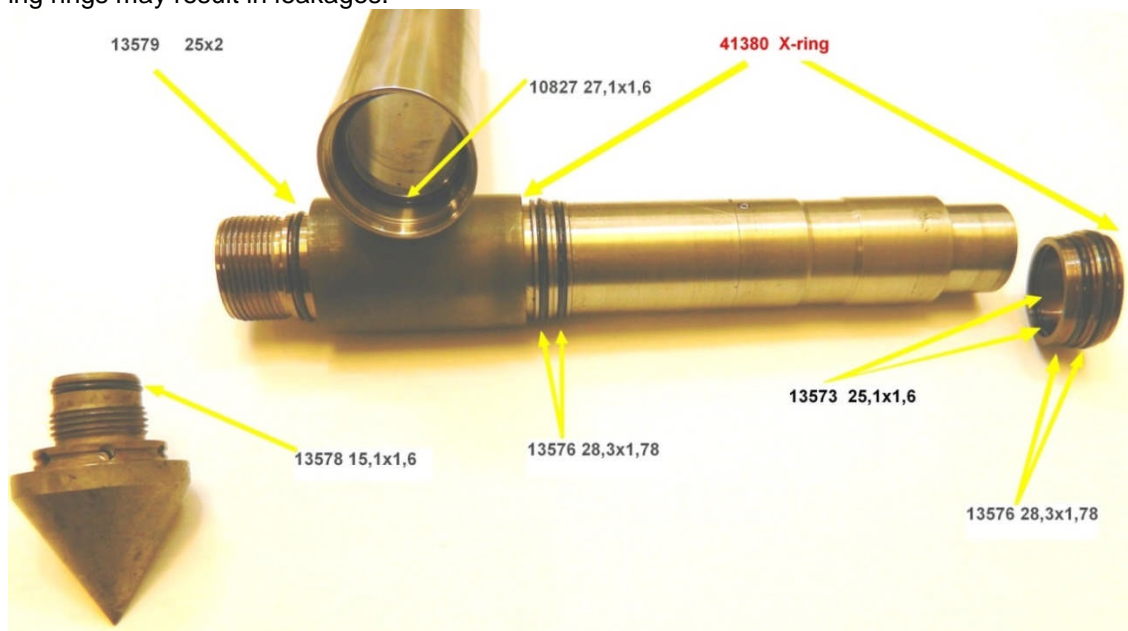

Fig. 31 – Sealing rings of the CPT GEOTECH NOVA probe.

12. Mount two O-rings and the X-ring on the measuring body and the O-ring on the end piece. Lubricate the rings slightly with vaselin. Note the different dimension of the O-ring on the end piece (thicker). Wrong types of sealing rings might affect test results or cause leakages.



Fig. 32 – Mount the sealing rings and lubricate slightly with vaselin.

13. Mount the two smaller O-rings inside the support ring. Mount two O-rings and one X-ring on the support ring. Lubricate the rings slightly with vaselin. Wrong types of sealing rings might affect test results or cause leakages.
14. Place the tensioning O-ring inside the friction sleeve.
15. Mount the support ring inside the friction sleeve.
16. Mount the friction sleeve assembly on the measuring body. The sleeve should now be easy to turn.
17. Store the probe in controlled environment with low humidity.

! NOTICE

No water is allowed in this part of the probe:

**! NOTICE**

Make sure that the equipment is clean and dry after each shift. Store saturated filter rings in a jar of glycerine or water.

5.2 Uploading data from memory probe after test

1. Remove the plug from the end piece of the probe, using the magnet that is attached to the memory read-out unit. Connect the round connector to the probe and the other end of the cable to your logging computer:



Fig. 33 – Uploading data from memory probe

2. Select "3 Back-up Memory" from the CPT-LOG main menu and upload data as described in the software manual.
3. Remove the cable from the probe and replace the plug in the end piece.

6 Installation and system maintenance

6.1 Installation

6.1.1 Hardware installation

For information on systems installed from factory on Geotech rigs, please refer to the rig manual.

The standard system is delivered with dedicated cables for connection of the interface to probe (directly or via a wireless channel), depth encoder, computer (RS232) and power supply. Hence the electrical installation is normally a simple plug-and-play operation. Please refer to product information above.

Depth encoder

The depth encoder 10755 is pre-set to give increasing depth when the wire is going inwards. If you desire the reverse (increasing depth when the wire is pulled out) you swap the wires on pin B and pin C in the cable connector that is connected to the interface. The depth encoder should be mounted with the wire entrance facing downwards, to minimise water intrusion. Please also refer to separate documents for information on other depth encoder types.

Acoustic system

The microphone is to be mounted on the yoke of the rig. It is used for pushing down the rod string, in addition to picking up the sound signal transferred from the probe assembly through the steel of the rod. There are four mounting holes on top of the microphone for metric M6 bolts.

RW system

Mount the receiver on the mast in line with the open end of the hollow rod string, white cone towards the transmitter.

Cable system

Thread the cable through the rod segments and connect it to probe and interface, using the cable adapters.

6.1.2 Software installation

Normally the system is delivered without logging computer. Standard Windows PC is to be sourced locally by the customer. Please refer to separate software manual for installation instructions. Note that separate drivers might be required.

6.2 Authorized Workshops

For support, calibration and repair please contact:

Ingenjörfirman Geotech AB
Datavägen 53
SE- 436 32 Askim
SWEDEN

info@geotech.se
+46 31 289920

For customs reasons, please declare **serial number** of probes, transmitters, interfaces etcetera when sending equipment for service.

6.3 Trouble Shooting

The trouble shooting table below is not complete, nor subject to any quality assurance, and thus published as indication only. Please feel free to revert with additional questions and suggestions.

Issue:	Finding possible causes:	Actions:
System		
Problems installing CPT-LOG	Refer to software manual.	Refer to software manual.
Error message "Interface test false..."	Check that the interface is connected and "POWER" lamp is glowing.	Connect and turn on if required.
	If USB adapter is used, check that driver is properly installed (use the computer "Control Panel" > "Device manager").	Install driver. In "Control Panel": check function and note COM port number. Refer to software manual for details.
	If USB adapter is used, check that the same COM port number is defined in both "Device Manager" and CPT-LOG.	In "Control Panel": check and note COM port number. In CPT-LOG: Select "1. Penetration" > Options > Interface Options. Select the same COM port. Click OK. Refer to software manual for details. From CPT-LOG version 5.22 COM ports will be automatically identified.
Problems synchronising memory probe	Open Device manager on the logging computer: "USB Serial Port" appears when connecting probe to USB port.	"USB Serial Port" appears with a "warning triangle" in Device manager: Driver not properly installed. Install driver (refer to software manual).
		No warning triangle: Software handling issue: refer to software manual.
	Open Device manager: "USB Serial Port" does not appear when connecting probe to USB port (could take up to one minute). Try different outlets.	USB cable not properly connected: Connect cable. USB connection, cable or probe broken: Replace or repair.
Software opens in Demo mode, when not connected to interface.	HASP key not connected.	Connect HASP key.
Software opens in "Demo mode", when connected to interface.	Interface without power or not properly connected.	See below. "Interface problem and no light from power lamp".
	If USB-RS232 adapter is used: Driver not properly installed.	Driver not properly installed. Install driver (refer to software manual).

Issue:	Finding possible causes:	Actions:
Interface problem and no light from power lamp.	Power switch off.	Switch on power.
	Power cable not connected or broken.	Check cable and connectors.
	Power source problems, e.g. external battery discharged.	Check power source with a multimeter. Charge external battery if required.
Depth and speed		
No depth reading during test	“Depth” lamp on interface is not flashing when depth encoder is manipulated.	Check cable and connections to depth encoder. Tighten connectors. Check depth encoder.
	“Depth” lamp on interface is flashing when depth encoder is manipulated.	Refer to software manual.
Incorrect depth reading during test	Different rod length from what is registered in the interface.	Change rod length in CPT-LOG.
	Different resolution of depth encoder from what is registered in the interface.	Change depth signal resolution in the interface. Contact Geotech for remote support.
	Different pushing mode from what is registered in the interface.	Change pushing type in CPT LOG: “Side clamping” / “Top mounted microphone”.
	“Flat line” diagram, typically one rod length.	Select “Pause” when manoeuvring pushing yoke beyond normal stroke.
Incorrect speed logging	Different resolution of depth encoder from what is registered in the interface.	Change depth signal resolution in the interface. Contact Geotech for remote support.
Acoustic signal		
Problem with real time readings	No, weak or intermittent sound from the transmitter.	Replace the batteries.
		Clean and remove rust from threads in joint probe – transmitter.
	Normal sound from the transmitter, but “Sound” and “Data” lamps not flashing.	Make sure that transmitter/rod is in direct contact with the microphone. Check microphone cable and connectors.
		Interface not properly set-up by software. Click “1 Penetration”. Select probe and set properties, (do not forget type “NOVA wireless”) and do the complete starting procedures, including zero reading.
Problem with real time readings occurring at great depth in abrasive soils only.	Use friction reducer or lubricate rod with bentonite in order to minimise damping and disturbing noise.	
	Use the memory function to upload data after test.	

Issue:	Finding possible causes:	Actions:
RW signal		
Problem with real time readings.	Weak batteries.	Replace the batteries.
	Check for rust and dirt in joint probe – transmitter.	Clean and remove rust.
	“Sound” and “Data” lamps not flashing.	Make sure that transmitter/rod is aligned with the receiver. Check receiver cable and connectors.
		Interface not properly set-up by software. Click “1 Penetration”. Select probe and set properties, (do not forget type “NOVA wireless”) and do the complete starting procedures, including zero reading.
Problem with real time readings occurring at great depth only.	Clean the rods inside, and make sure that surfaces are dry and smooth. Rods with stainless steel lining are recommended.	
		Use the memory function to upload data after test.
Cable system		
Problem with real time readings.	Check for corrosion, dirt and poor connections, check if cable is damaged.	Clean and repair if needed.
Pore pressure (u)		
Negative pore pressure readings.	Soil type with naturally negative pore pressure, e.g. silt or frozen material.	No action – result is correct!
	Over pressure during zero reading.	Let the probe rest a while after de-airing and mounting the tip.
No changes or “slow reactions” on pore pressure curve.	Filter ring not properly saturated or probe cavities not completely de-aired.	Change to new saturated filter ring and de-air probe according to instructions above.
	De-airing medium was “sucked out” by soil type with naturally negative pore pressure, e.g. silt or frozen material.	Pre-drill through critical layer.
		Protect the filter with a rubber membrane while penetrating dry crust.
		Use slot filter with grease and oil (refer to instructions above).
Strange pore pressure values.	Incorrect values in “Cone database”?	Make sure that correct scaling factor is correctly registered in the cone database.
Point resistance (q_c)		
Strange q _c readings.	Incorrect values in “Cone database”?	Make sure that area and scaling factor from the calibration certificate are correctly registered in the cone database.
	Sensor exposed to external force during zero reading?	Make sure all sensors are unloaded during zero reading.
	Check zero reading before and after test.	If zero values have changed outside of tolerance, the probe should be sent for calibration.



© 2015 Ingenjörfirman Geotech AB
Datavägen 53 • SE-436 32 Askim • SWEDEN
Phone +4631289920 • Fax +4631681639
www.geotech.eu • info@geotech.se